



arkè®

by **ALBINI & FONTANOT®**

English

ASSEMBLY INSTRUCTIONS

KARINA

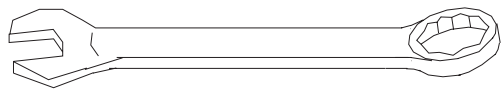

19 mm

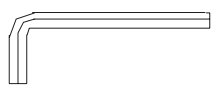

10 13

3 5 6 10 mm

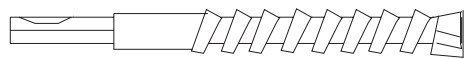
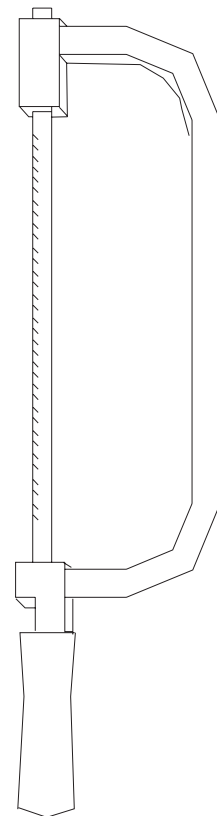

Ø 8x120 Ø 14x150 mm

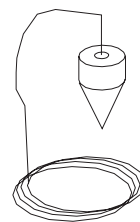

Ø 6.5 mm

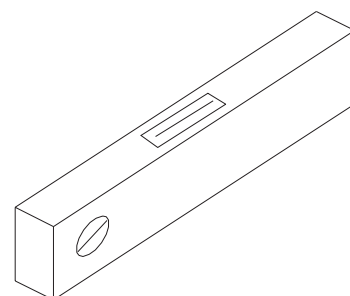
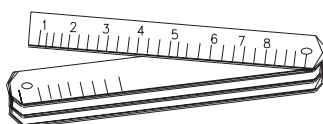

Before starting the assembly process, unpack all components of the staircase. Lay them out on a large surface and check the quantity of all the pieces, by consulting the table TAB.1 (A = Code, B = Quantity). Inside the staircase box you will also find a video tape which we suggest watching before proceeding to assemble. For the USA only: call the customer support line at 1-888 STAIRKT, should you have any case of need.

Assembly

1. Carefully measure the floor-to-floor height.
2. Calculate the rise: subtract 22 cm (8 1/2") from the floor-to-floor height you measured, 2) divide this value by the rises number minus one. Example: for the measured floor-to-floor height of 268cm and a staircase with 12 rises; $(268-22)/(12-1)=22,36$ (8'9 1/2" -8 5/8")/(12-1)=8 3/4".
3. Determine the fixing position of the support N19 (fig. 1) keeping in mind two points: 1) the rise, calculated previously, also contains the tread depth (L19 or L20) (fig. 2). 2) Position the support N19 keeping in mind the opening feature (fig. 3).
4. Drill with the drill bit \varnothing 14.
5. Assemble on the floor, with a rectilinear line, the supports N19, N18, N17 and N16 keeping in mind the calculated rise previously. Use the parts C15, B71 and B75 (fig. 1). Tighten sufficiently keeping in mind that the supports N19, N18, N17 and N16 have still to rotate for the configurations B, C, D.
6. Lift and position the structure with the support N19 which has to touch the floor (fig. 4). If the stair place is too tight, it is suggested to rotate some supports.
7. Fix the support N19 completely, by using the part C39 (fig. 1).
8. Place on the floor, in sequence, one left tread (L19), one right tread (L20) and so on. Now determine which will be the first tread from the top.
9. Fix the treads (L19, L20) completely starting from the top until to the support N16, by using the parts C40 (fig. 1).
10. 1. The configuration A (rectilinear) doesn't need any further changes (fig. 3).
2. The configurations B or C need a rotation of 13° (fig. 3).
3. The configuration D needs a rotation of 18° (fig. 3).
11. To rotate the supports of 13° or 18° you have to proceed as follows:
 - a. Set out with a pencil, at the connection point of two supports, two vertical lines at a distance of 9mm (0,35") (to rotate 13°, configuration B or C) (fig. 6) or 13mm (0,51") (to rotate 18°, configuration D) (fig. 8).
 - b. Loosen the parts C15, one support by one, starting from the top and rotate till one of the lines matches the one of the top according to the direction of rotation.
 - c. Tighten the parts C15 completely (fig. 1).

Assembly of the Railing

12. Cut along the shape (fig. 5) for the configurations A, B, C or the shape (fig.7) for the configuration D.
13. Decide where assemble the railing (inside or outside) (fig. 3) and pierce the treads (L19, L20) with the drill bit 6,5 using the template only for the rectilinear sides. To find the fixing point on the short side of the winding treads (L19, L20) maintain the same distance as the one between the balusters (C12) to assemble on the long side of the tread (fig. 3).
14. Assemble and fix the parts F23 by using the parts C14, B83, B86, C13, B02 (fig. 1).
15. Assemble the parts C28 by using the parts C13, B02 and insert them into the balusters (C12) (fig. 1).
16. Insert the balusters (C12) into the parts F23, blocking them by the part B02.
17. The first balusters (C12) of the long side of every tread (L19, L20) have to be cut.
18. Tighten the part C28 completely, by using the part B02 (fig. 1). For a correct assembly twist the key at about 90° from the contact point.

Final Assembly

19. Control the vertical line of the whole stair and, if necessary, correct it by moving the support N16 (fig. 1).
20. Disassemble the first tread (L19 or L20) and drill the floor with a \varnothing 14 tip in relation to the present holes on the support N16 (fig. 1).
21. Insert the parts C39 and tighten completely (fig. 1).
22. Reassemble the first tread (L19 or L20) and fix on the floor, in relation to the first baluster (C12), the part F01, by drilling with a \varnothing 8 tip. Use the parts B11, B12, B83 and B02 (fig. 1).
23. Insert the baluster (C12) and tighten the part B02 (fig. 1).

We would be grateful, if you could send us any possible suggestion by visiting our Internet Site:
www.arke.ws

TAB. 1

A	B
B02	62
B11	2
B12	2
B71	20
B75	40
B83	62
B86	30
C12	15
C13	60
C14	30
C15	20
C28	15
C39	4
C40	44
F01	2
F23	30
L19	6
L20	5
N16	1
N17	1
N18	8
N19	1

FIG. 1

FIG. 7

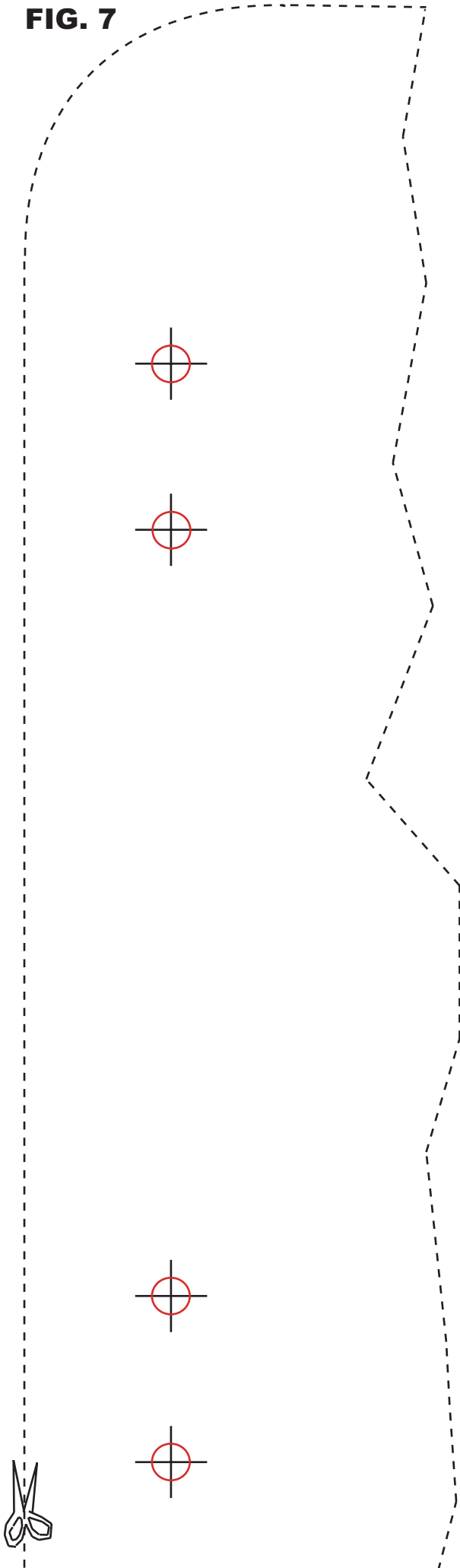
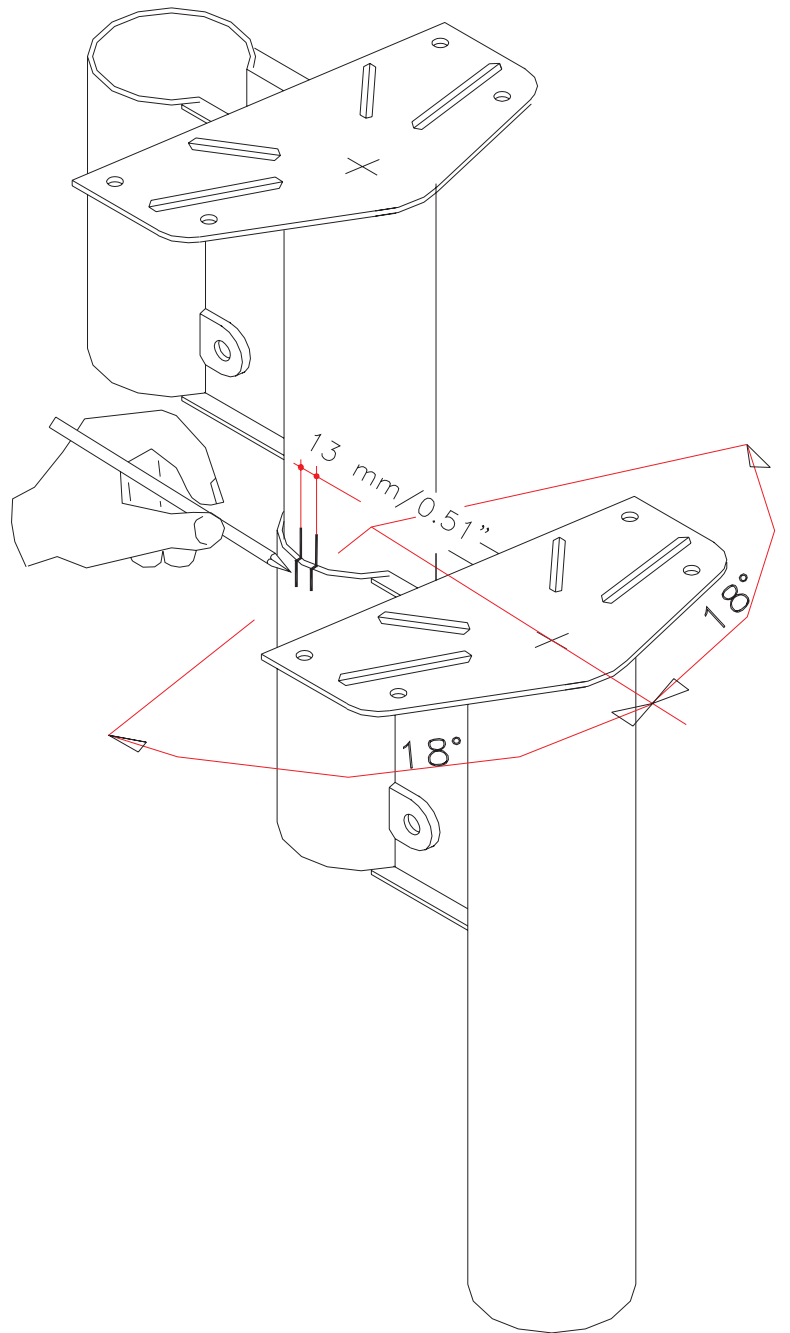

FIG. 8



BALUSTRADE

